



SOLID-DRILLED THERMOWELLS

PCi solid-drilled thermowells are manufactured from single-piece forgings in a wide variety of materials.

Special drilling techniques produce a high quality internal bore finish with superb concentricity. External surfaces are fine machine-finished.

Solid-drilled thermowells are available with a full range of process connections and can be fitted with a welded lagging extension.



A selection of fabricated and solid-drilled thermowells

www.pci-instruments.com..... +44 (0) 1704 509090..... sales@pci-instruments.com.....



ORDERING MATRIX

Locate the order code for your specification and enter it into the appropriate box. See the previous pages for more information about each option.

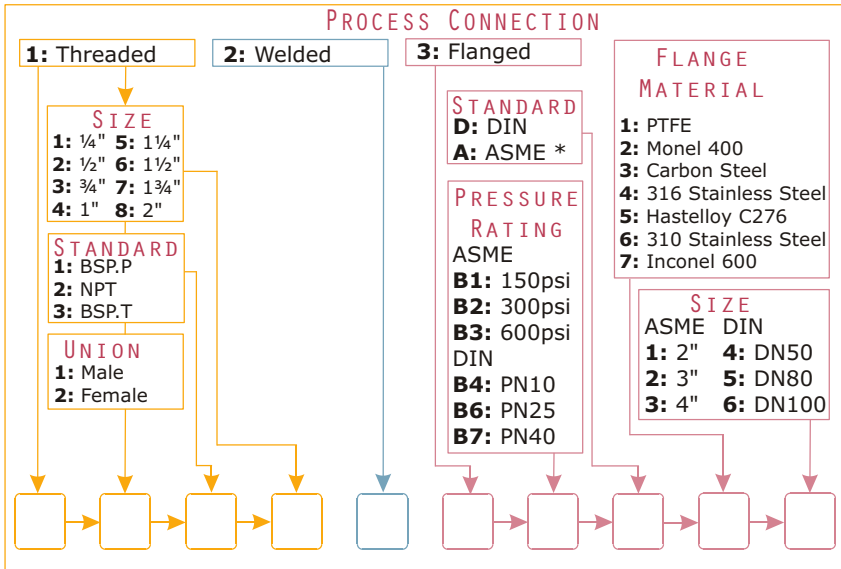

* JIS Standard also available on request

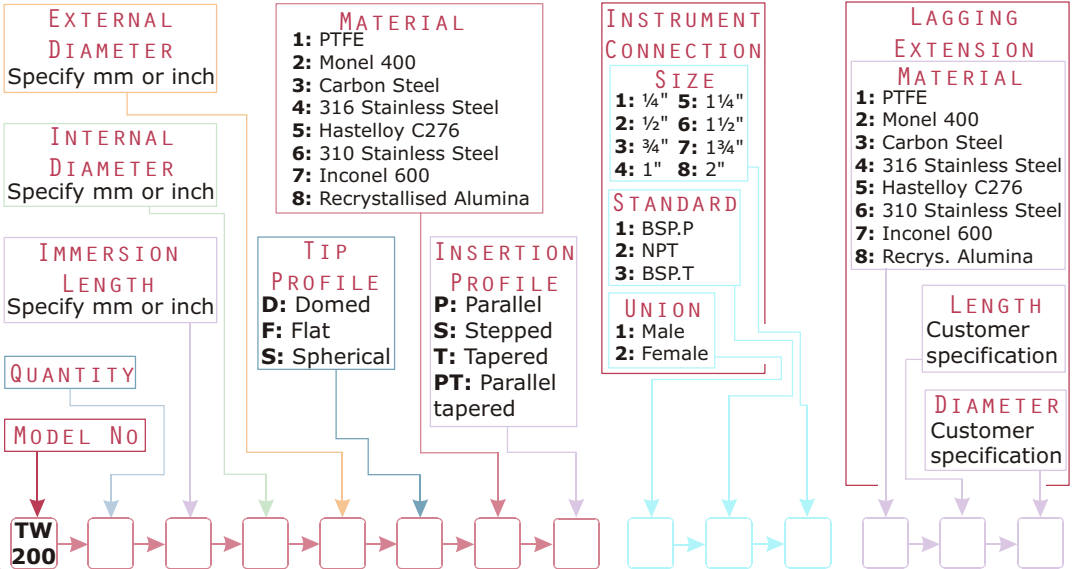

Can be fitted to

THPT

When you have completed the specification of your thermowell above, copy it onto the specification for the instrument you wish it to be fitted to. The two specifications together complete the order for your instrument.